



# AUTOMATIC BENDERS DURABEND 211



2D Bar Coding Optional



The KRB DuraBend 211 single headed double bender is designed to speed up the bending process of rebar. The machine has a robotic clamp on each side of the bender to position the bar for the proper bend. The DuraBend eliminates 2- and 3-man bending and will

automate the bending and material handling process. There is no need for a highly skilled operator, the controls are fully conversational and easy to operate. Setup is simple and quick.





KRB  
 1058 Cool Creek Road  
 Wrightsville, PA 17368  
 Phone: 717-252-3667  
 Fax: 717-252-9247  
 info@krbmachinery.com



## General Specifications:

- Bend speed variable with VFD on electric and servo motors
- Pneumatic operated discharging system.
- Fully conversational computer control with 2D bar scanning and downloading capabilities. The control provides a picture, on the screen, verifying the programmed part is correct. The controller allows for 36 lines of programming input. There are also hot keys for bend angle input.
- Roller conveyor for loading
- All electrical controls are U.L. (Underwriters Laboratories) and c.U.L. Listed.
- All wiring meets N.E.C. (National Electrical Code) Standards.
- All electrical enclosures meet NEMA 4/12 rating. (Watertight, dust tight, oil tight).
- Complies with the requirements of the EU Machinery Directive
- Estimated average power consumption 12 kW/h

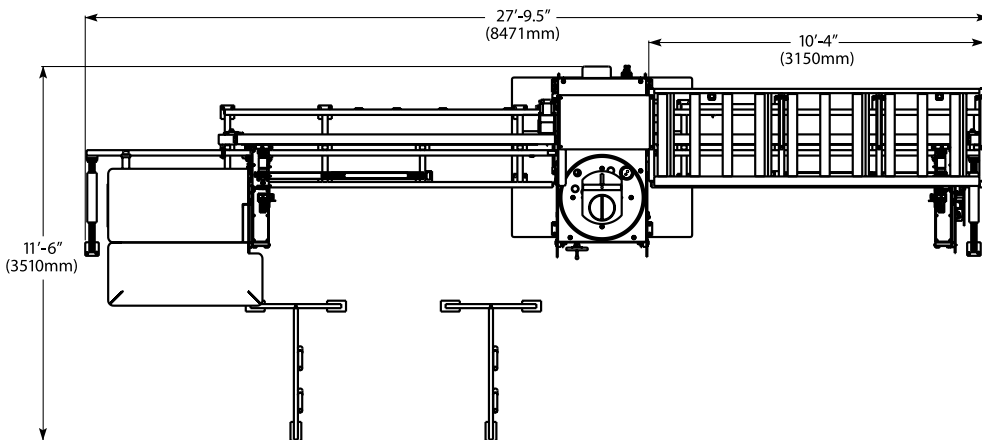

CAPACITY CHART Grade 60 or 65kg/mm <sup>2</sup>		
BAR SIZE		QTY OF BARS
IMPERIAL	METRIC	
3	10mm	9
4	12mm	7
5	16mm	6
6	20mm	6
7	22mm	5
8	25mm	4
9	28mm	3
10	32mm	2
11	35mm	2



Handles column offset bars easily with optional tooling

